

## STACK EMISSION AIR DUST ANALYSIS

### EP 1000A, SERES ENVIRONNEMENT SOLUTION FOR

- continuous,
- laser backscattering,

### MEASUREMENT OF DUST IN STACK AIR EMISSION.

#### EP 1000A benefits :

- ✓ Increased protection
- ✓ Very flexible to use
- ✓ Precise and reliable measurement
- ✓ No predictive maintenance over the years
- ✓ QAL1 – TÜV certification

## BACKGROUND & APPLICATIONS

**An outstanding and proven know-how** for stack dust emission analysis :

- Easy to install, unibody aluminium enclosure
- Receiver device insensitive to alignment
- Instantaneous and continuous measurement directly in the emission flow and requiring no sampling system or separate receiver
- Relative insensitivity to water droplets, stack emission flowrate and temperature, to ambient light thanks to beam modulation and to thermal variations (internal regulation)
- Continuous microprocessor control of the laser diode

#### Applications in a wide range of industries :

- Power plant, industrial boilers, incinerators,
- Cement & asphalte plants, paper mills,
- Petrochemical plants, steel industry, glass works

EP 1000A laser technology is the high performance solution for classified industries required to fit their stacks with dust control systems conforming to emission air regulations in force. It has been qualified by the French Ministry for Industry & Environment..



## ADVANTAGES

**Efficient & sturdy design**

**User-friendly interface**

**No drift in the measurement**

**Excellent signal linearity, especially at low concentrations**

**Low life cycle cost**

**Conforming to European Directives**

**Options : protective flare shield, air turbine, remote display keypad, ...**

**Compatibility with SERES environnement range of emission gas analysers**

## PRINCIPLE - DUST ANALYSIS by LASER BACKSCATTERING

The stack dust analyser consists of a unique **emitter / optical receiver housed in a single enclosure** installed at **one side of the chimney**.

- The emitter points a **laser beam** throughout the air emission flow within the stack,
- The receiver measures the quantity of **light backscattered** by the suspended dust particles present in the flue.

To prevent any disturbance, the laser beam is either exited outside the stack or captured in a light trap mounted on the opposite wall of the chimney (option).

### Laser beam backscattering :

- ✓ when emitted across the atmosphere, a laser beam is backscattered by suspended dust particles,
- ✓ towards a photo-cathod that will yield an electrical signal corresponding to the actual dust concentration.

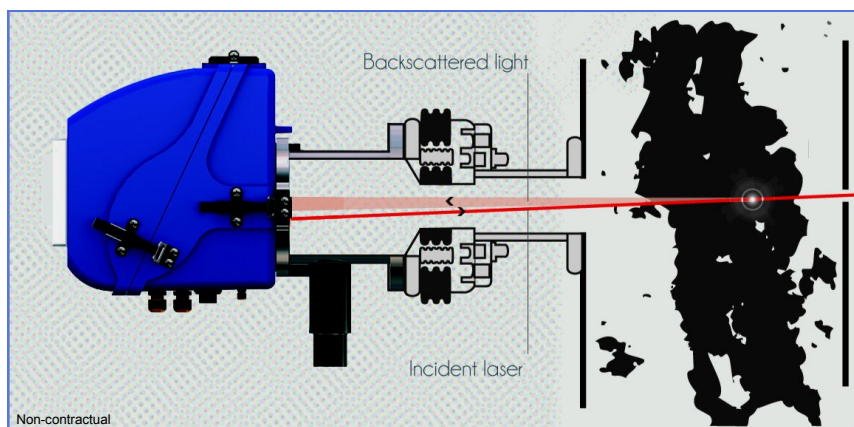

## TECHNICAL SPECIFICATIONS

### CONSTRUCTION & ENVIRONMENT

Dimensions / Weight	230 x 220 x 290 mm (L x H x P) / 15 kg
Housing	Aluminium, IP 65, with bi-directional rotative openings for easy service access
Operating T°	from -25°C to +55°C
Installation	Internal stack diameter : Ø > 50 cm Mounting on chimney wall : DN80 PN16 flanges Easy alignment

### ELECTRICAL SUPPLY

Power supply	230 VAC (+6 / -10%) or 110 VAC
Consumption.	20 W

### ANALYSIS

Method & Parameter	Laser backscattering Dust in air, all types
Measuring element	Laser diode 1 mW average, 660 nm Classe 3A Laser
Life time	Average life of the laser diode : 3 to 5 years
Unit	mg/m3
Measuring ranges	from 1 mg/Nm3 to 200 g/Nm3
Particle Ø	Dust particles detected : Ø > 5 µm
Detection limit	Minimum detection limit : 0.5 mg/Nm3
Sensitivity	Automatic gain commutation
Linearity	Excellent linearity, especially for low concentrations
Measurement drift	Negligible

### OPERATION, ALARMS & CONNECTIVITY

Relay	Built in (RCT contact, 440 VA - 2 A, 220 VAC)
Alarms & faults	Relays, indicator lights and digital output
Calibration	Possibility of calibration for various types of processes
Internal zero	Automatic adjustment (Auto zero)
External zero	Menu « zero measure » when process at stop
User interface	Local Display / Keypad (basic configuration) 7 menus for installation, maintenance, calibration, ...
Transmission	4 - 20 mA signal output to an acquisition unit RS 485 or RS 422 ModBus
Safety	Positive safety for fault relays
Mains power control	Indicator light

### CONFORMITY

Compliance	QAL 1 - TÜV certification to European Directives
------------	--

### OPTIONS

Remote display / keypad with autonomus power supply  
Blowing unit (air turbine) for air sweeping of the optics  
Light trap with air turbine for stack overpressure or with protective device for low concentrations or stack underpressure  
Optical calibration device for easy routine verification of stability / drift

### ENGINEERING / TURNKEY PROJECTS (on request)

Compatibility with SERES environnement range of emission gas analysers..  
Autres options / study / integration : please contact us